

The role of TNF- α in chronic inflammatory conditions, intermediary metabolism, and cardiovascular risk

Calin Popa,^{*,†} Mihai G. Netea,^{*} Piet L. C. M. van Riel,[†] Jos W. M. van der Meer,^{*} and Anton F. H. Stalenhoef^{1,*}

Departments of General Internal Medicine* and Rheumatology,[†] Radboud University Nijmegen Medical Center, Nijmegen, The Netherlands

Abstract The recent insight that inflammation contributes to the development of atherosclerosis and type 2 diabetes mellitus constitutes a major breakthrough in understanding the mechanisms underlying these conditions. In addition, it opens the way for new therapeutic approaches that might eventually decrease the prevalence of these public health problems. Tumor necrosis factor- α (TNF- α) has been shown to play a key role in these processes and thus might be a potential therapeutic target. Increased concentrations of TNF- α are found in acute and chronic inflammatory conditions (e.g., trauma, sepsis, infection, rheumatoid arthritis), in which a shift toward a proatherogenic lipid profile and impaired glucose tolerance occurs. Although therapeutic blockade of TNF- α worsens the prognosis in patients with abscesses and granulomatous infections, this strategy is highly beneficial in the case of chronic inflammatory conditions, including rheumatoid arthritis. **Current investigations assessing the impact of anti-TNF agents on intermediary metabolism suggest that TNF- α blockade may improve insulin resistance and lipid profiles in patients with chronic inflammatory diseases.**—Popa, C., M. G. Netea, P. L. C. M. van Riel, J. W. M. van der Meer, and A. F. H. Stalenhoef. **The role of TNF- α in chronic inflammatory conditions, intermediary metabolism, and cardiovascular risk.** *J. Lipid Res.* 2007. 48: 751–762.

Supplementary key words tumor necrosis factor- α • lipids • anti-tumor necrosis factor • insulin resistance

INTRODUCTION

The metabolic syndrome, also known as syndrome X, represents a constellation of metabolic abnormalities that includes central obesity, insulin resistance, glucose intolerance, dyslipidemia, and hypertension (1). Each of these features is known to augment the risk of developing diabetes mellitus (DM) and cardiovascular disease. For decades, both exogenous factors, such as diet, sedentarism,

and alcohol consumption, and genetic background were considered to constitute the major determinants of disturbances in intermediary metabolism. Consequently, lifestyle changes and genetic familial screening were advocated to combat the onset and development of the metabolic syndrome, diabetes, and cardiovascular disease. However, the appearance of the metabolic syndrome in people with normal dietary habits and without a particular genetic background raised the possibility that other pathogenetic factors contribute to the development of this syndrome. Further studies indicated that inflammation constitutes the “missing puzzle piece” in the pathogenesis of the metabolic syndrome.

Evidence of a link between inflammation and lipid metabolism was provided by studies showing dyslipidemia and insulin resistance during acute inflammation, as occurs in septic shock or trauma (2–5). In turn, hyperlipidemia was shown to inhibit the acute inflammatory response (6). In addition, patients with chronic inflammatory diseases such as rheumatoid arthritis (RA) were often described to have a dyslipidemic profile and altered glucose tolerance (7, 8). However, not until the past decade did the role of inflammation in the development of the metabolic syndrome become documented or its importance accepted (9). Additionally, the contribution of inflammation to the development of both early and late atherosclerotic lesions led Ross (10) to affirm that atherosclerosis is an inflammatory disease. Other evidence came from studies showing that adipose tissue secretes inflammatory cytokines, which in turn contribute to impaired glucose tolerance, insulin resistance, and type 2 diabetes (11, 12). Finally, the level of circulating inflammatory markers such as C-reactive

Abbreviations: apoA-I, apolipoprotein A-I; ATGL, adipocyte triglyceride lipase; CETP, cholesteryl ester transfer protein; CYP7A1, cholesterol-7 α -hydroxylase; DM, diabetes mellitus; HSL, hormone-sensitive lipase; IL-6, interleukin-6; IRS-1, insulin receptor substrate-1; JNK, c-jun-NH₂-terminal kinase; LPS, lipopolysaccharide; RA, rheumatoid arthritis; RCT, reverse cholesterol transport; TG, triglyceride; TNF- α , tumor necrosis factor- α ; TNF-RI, tumor necrosis factor receptor type I.

¹To whom correspondence should be addressed.

e-mail: a.stalenhoef@aig.umcn.nl

Manuscript received 24 July 2006 and in revised form 17 October 2006 and in re-revised form 27 December 2006 and in re-revised form 2 January 2007.

Published, JLR Papers in Press, January 2, 2007.
DOI 10.1194/jlr.R600021-JLR200

protein and interleukin-6 (IL-6) independently was found to predict the risk of future cardiovascular events in the general population (13, 14).

Among many inflammatory markers, tumor necrosis factor- α (TNF- α) emerged as a key cytokine that influences intermediary metabolism. TNF- α was originally described as cachectin, a protein that was demonstrated to be involved in the development of cachexia (15). Later studies described the proatherogenic changes in lipid metabolism induced by this cytokine (4, 16). In animal models, administration of TNF- α led to severe impairment of glucose tolerance and insulin sensitivity (17). Thus, TNF- α might serve as a therapeutic target in these disorders. Treatment of sepsis with agents that block TNF- α actions was proven to worsen these conditions (18), whereas in the case of chronic inflammation, such as in the joints of RA patients, this therapy was highly beneficial (19, 20). Given these facts, the evaluation of metabolic markers in patients with chronic inflammatory conditions during anti-TNF therapy is warranted.

This review will focus on the role of TNF- α in the development of dyslipidemia and insulin resistance as important features of the metabolic syndrome, which may eventually augment the risk of cardiovascular diseases and type 2 DM. Patients with RA have 1.5–2 times higher risk of cardiovascular morbidity and mortality, and chronic systemic inflammation is likely to play a crucial role in this respect. Therefore, the impact of anti-TNF strategies on intermediary metabolism in these patients will be discussed.

INTERMEDIARY METABOLISM: ACUTE VERSUS CHRONIC INFLAMMATORY STATE

During acute conditions, the organism reacts quickly through a variety of mechanisms that are meant to set the different homeostatic systems at new thresholds that are eventually decisive for the outcome. These modifications also include changes in lipid metabolism (2–4) that eventually have beneficial consequences for the host. Accordingly, an increase in lipoprotein concentrations during the acute phase response was shown to neutralize the toxic effects of lipopolysaccharide (LPS) in both in vitro and in vivo models, conferring on them a crucial role in host defense during endotoxemia (4, 21, 22). Although LPS binds and activates monocytes more rapidly than lipoprotein binding and neutralization occurs, the infusion of lipoproteins was indicated to accelerate the kinetics of the neutralization of LPS, providing some advantage (23). Interestingly, the phospholipid content was reported to correlate with the ability of lipoproteins to neutralize LPS. The increase in serum triglycerides (TGs) and glucose during acute inflammatory conditions may also provide extra nutrients for the increased metabolic needs of cells involved in host defense and tissue repair. In contrast, hyperglycemia, even acutely, has been extensively demonstrated to be associated with an impairment of host defense, including decreased polymorphonuclear mobilization, chemotaxis, and phagocytic activity (5).

Despite all of these beneficial acute effects, the longer the persistence of inflammatory markers, such as TNF- α , the more will they induce changes in both lipid and glucose metabolism that are likely to have detrimental consequences for the host (Fig. 1). The lipid changes induced by TNF- α are proatherogenic in terms of both quality and quantity; therefore, the persistence of these modified lipids in the circulation will promote the development of atherosclerotic lesions. The sustained increase in glucose and TG plasma concentrations will have important consequences for glucose homeostasis, altering glucose tolerance and promoting hyperinsulinemia and an insulin resistance state.

Chronic inflammatory conditions have been shown to be associated with a proatherogenic lipid pattern and altered glucose tolerance. Patients with inflammatory diseases such as RA and systemic lupus erythematosus have lower HDL and apolipoprotein A-I (apoA-I) and higher apoB, total cholesterol/HDL-cholesterol ratio, and lipoprotein [a] plasma concentrations (7, 24, 25). Consequently, they have more atherosclerotic lesions, impaired endothelial function, and increased carotid intima media thickness, which is associated with a higher mortality attributable to cardiovascular diseases than in the general population (24, 26, 27). In addition, it was recently found that especially RA patients show an impairment of glucose handling and an enhanced insulin response after intravenous glucose loading (8). In this light, an exploration of the contributions of inflammation in general and TNF- α in particular to the modified intermediary metabolic pattern of chronic inflammatory diseases is warranted.

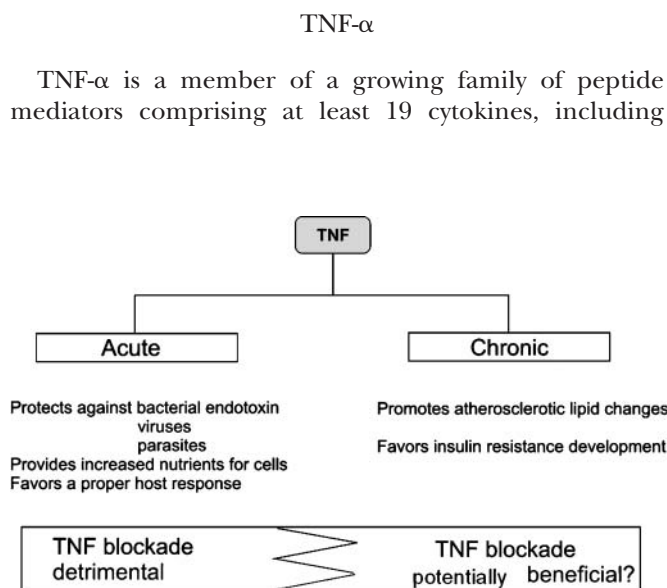

Fig. 1. The acute and chronic effects of tumor necrosis factor- α (TNF- α) on intermediary metabolism and their consequences for the host. Although anti-TNF agents have been proven to be detrimental in acute conditions, they might be beneficial in combating metabolic syndrome features in the case of chronic inflammatory diseases.

lymphotoxin- α , Fas ligand, and CD40 ligand. TNF- α has important proinflammatory properties, which play crucial roles in the innate and adaptive immunity, cell proliferation, and apoptotic processes. The cytokine is produced by different kind of cells, including macrophages, monocytes, T-cells, smooth muscle cells, adipocytes, and fibroblasts. Biological responses to TNF- α are mediated by ligand binding via two structurally distinct receptors: type I [tumor necrosis factor receptor type I (TNF-RI); p55] and type II (TNF-RII; p75), which are present on the membrane of all cell types except erythrocytes. The two receptors differ significantly in their binding affinities as well as in their intracellular signaling pathways. Upon stimulation, the intracellular domain of TNF-RI binds to the TNF receptor-associated death domain (TRADD) protein, which can further activate either the apoptotic pathway, via the Fas-associated death domain (FADD) protein, or the proinflammatory pathway, via TNF receptor-associated factor 2 (TRAF2) and receptor-interacting protein, resulting in the activation of nuclear factor- κ B. In contrast to TNF-RI, TNF-RII is unable to activate the TRADD/FADD pathway and signals only through the TRAF2-associated pathway. Of note, studies have indicated the presence of an important cross-talk between the two receptors, which is likely to be responsible for the net response of a cell upon TNF- α stimulation (28). Accordingly, TNF-RI is mainly responsible for mediating the inhibitory effects of TNF- α on the insulin receptor signaling pathway (29, 30), whereas TNF-RII deficiency alone does not affect insulin sensitivity but may potentiate the effects of TNF-RI deficiency in animals lacking both TNF receptors (31). In addition, the lipolytic effect of TNF- α on TGs is mediated mainly via TNF-RI (32). Besides membrane-expressed TNF receptors, plasma soluble TNF receptors can also modulate the actions of TNF- α . In agreement with this, TNF-RII is likely to play an important role in human obesity by neutralizing TNF- α actions; therefore, it was suggested to be the best predictor of adipose TNF- α activity in these subjects (33). Moreover, patients with peripheral vascular disease or myocardial infarction survivors were found to have increased plasma TNF-RII concentrations (34). Therefore, the measurement of soluble TNF-RII might be of relevance when assessing the contribution of TNF- α to the pathogenesis of these conditions, whereas TNF-RI remains the main membrane-bound receptor to signal TNF- α actions.

TNF- α AND LIPID METABOLISM

TNF- α is a pleiotropic cytokine, and its role in inflammation and metabolism is complex. Together with other proinflammatory cytokines, chemokines, and various immune cells, TNF- α has emerged as an important contributor to the development of atherosclerotic lesions by promoting the expression of adhesion molecules on endothelial cells, the recruitment and activation of inflammatory cells, and the initiation of the inflammatory cascade inside the arterial wall (10, 35). TNF- α has been

demonstrated to directly interfere with the metabolic pathways of TGs and cholesterol (4, 16, 36), which will be discussed in detail below. Therefore, TNF- α may gain a special importance when referring to atherosclerotic lesion development and the risk of acute cardiovascular events.

TNF- α and TG metabolism

Patients with acute inflammatory disorders and sepsis, in which increased TNF- α concentrations occur, have been shown to have increased TG concentrations early during the acute episode of the disease (37, 38). In addition, hypertriglyceridemia has also been observed in cancer and chronic infections such as acquired immunodeficiency syndrome, conditions in which increased concentrations of TNF- α may be present (39, 40). Finally, the administration of TNF- α and endotoxin (LPS) to mice and humans results in an acute increase of plasma TG concentration of \sim 85% (36, 41, 42). The effects of TNF- α on plasma TG occur through effects on both adipose tissue and liver TG metabolic pathways. Accordingly, TNF- α increases plasma TG by increasing the concentration of FFAs (43), the substrate for TG synthesis, and by diminishing the clearance of TG-rich lipoproteins (VLDLs) from the circulation (42) (Fig. 2).

TNF- α increases FFA production from both adipose tissue and liver. In human adipose tissue, *in vitro* studies demonstrated that TNF- α stimulates lipolysis. This effect is mediated mainly via TNF-RI (32) and involves the activation of several kinases of the mitogen-activated protein kinase family of signaling kinases, including extracellular signal-related kinase 1/2 (or p44/42) and c-jun-NH₂-terminal kinase (JNK) (44). There are several pathways through which TNF- α exerts its lipolytic effects. First, after the activation of extracellular signal-related kinase 1/2, an increase in the intracellular concentrations of cAMP occurs that further activates protein kinase A, which in turn phosphorylates hormone-sensitive lipase (HSL) and perilipins, adipocyte proteins situated on the surface of the lipid droplet (45). Perilipins were recently shown to play a crucial role in the induction of lipolysis by regulating the substrate accessibility for HSL and adipocyte triglyceride lipase (ATGL), the main lipolytic enzymes (45–47). After their phosphorylation, which may also occur directly via JNK and p44/42, perilipins translocate away from the lipid droplet, allowing access for HSL and ATGL to hydrolyze the TGs inside. Although ATGL exerts its hydrolyzing activity only on TG, HSL has a 10-fold higher activity on diglycerides, resulting from the previous lipolytic step. Second, TNF- α downregulates the expression of perilipins (46), which may further enhance the lipolysis in adipocytes. In addition, TNF- α can suppress the expression of HSL (48) and ATGL (49), but without changes in its net lipolytic effects (50). Finally, through activation of the p44/42 kinase, TNF- α may inhibit early insulin receptor signaling, thereby counteracting the anti-lipolytic role of the hormone (51). In addition, in rodents, TNF- α may inhibit the expression of Gi-protein-coupled adenosine receptors present on the surface of adipocytes,

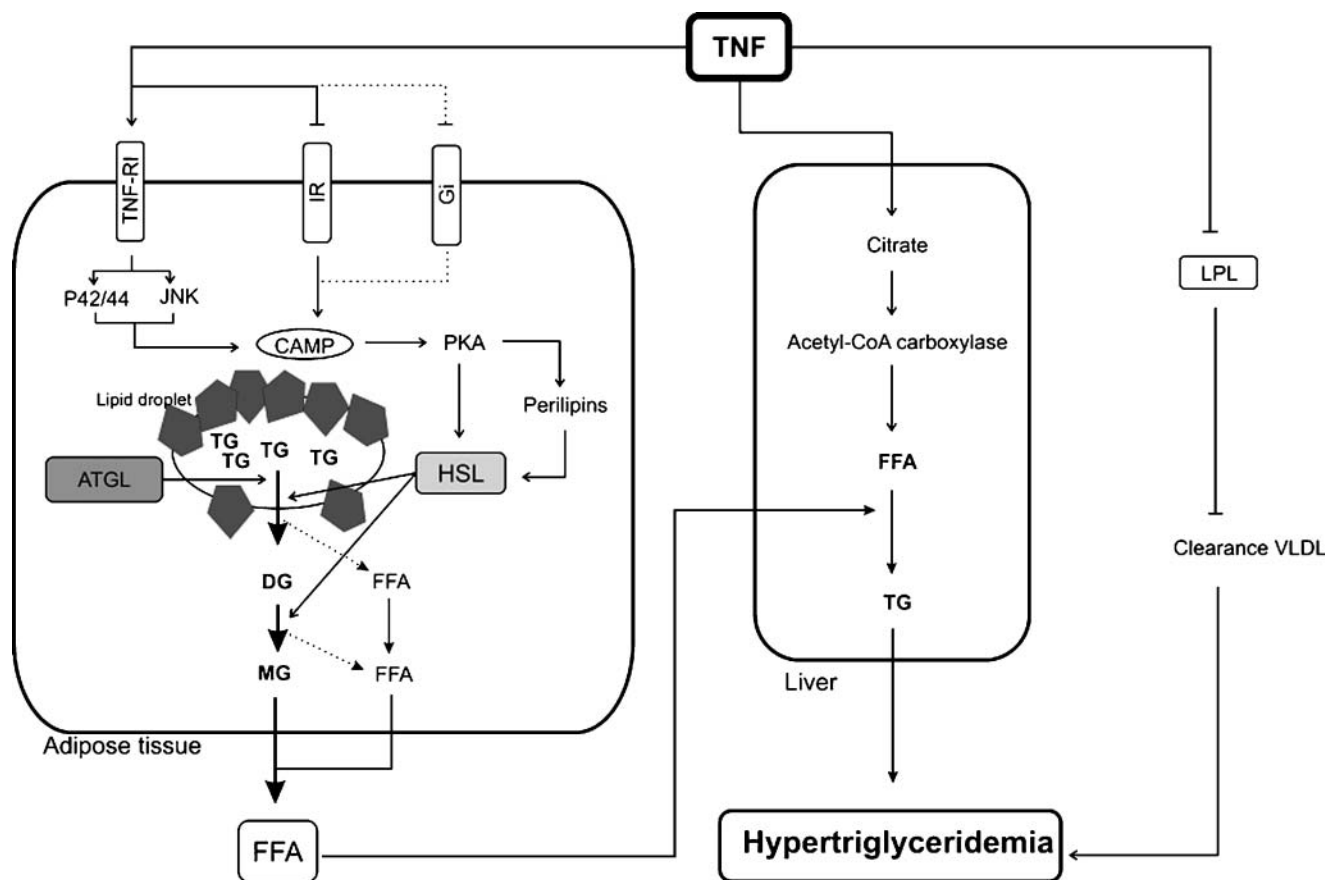

Fig. 2. TNF- α -induced hypertriglyceridemia. The different pathways are represented. To date, the Gi-dependent pathway (dotted lines) has been shown only in rodents. ATGL, adipocyte triglyceride lipase; DG, diglyceride; Gi, Gi-protein-coupled adenosine receptor; HSL, hormone-sensitive lipase; IR, insulin receptor; JNK, c-jun-NH₂-terminal kinase; MG, monoglyceride; p44/42, extracellular signal-related kinase 1/2; PKA, protein kinase A; TG, triglyceride; TNF-RI, tumor necrosis factor receptor type I.

thereby suppressing the antilipolytic effect of adenosine (52). However, this effect could not be demonstrated in human fat cells (53). As a result of these actions, FFAs are released from adipocytes into the circulation and may further constitute the substrate required for TG synthesis in the liver. Of note, hypertriglyceridemia constitutes an important prestep in the development of glucose intolerance and insulin resistance, which will be addressed below.

Hepatic TG production is increased in both human and murine studies, as demonstrated by the increase of TG-containing VLDL particles after TNF administration (36, 41, 42). However, insights into the mechanisms responsible for this effect were based only on animal models. Such mechanisms are represented by an increase in the availability of FFAs released by stimulated lipolysis in peripheral adipose stores as well as de novo fatty acid synthesis in the liver. Cytokines can stimulate hepatic TG synthesis by various mechanisms. TNF- α , IL-1 β , and IL-6 acutely increase hepatic levels of citrate, an allosteric activator of acetyl-CoA carboxylase, the rate-limiting enzyme in FFA synthesis (54, 55). In contrast, IFN α , using an unknown mechanism, activates acetyl-CoA carboxylase without increasing citrate levels and has a synergistic effect with TNF- α , IL-1 β , and IL-6 on FFA production (4, 55). This

suggests that TNF- α can induce these changes either directly or indirectly, by increasing the level of other pro-inflammatory cytokines, such as IL-1 β and IL-6. Finally, the hepatic enzymes involved in the esterification of fatty acids with glycerol are not increased after TNF- α treatment, suggesting that hepatic TG content is driven by the availability of the chief substrate, the fatty acids.

Another mechanism through which TNF- α can increase plasma TG concentrations in both humans and rodents is the inhibition of LPL activity (4, 16, 42). The inhibitory effect is seen at both the transcriptional and posttranscriptional levels, leading to a decrease in the clearance of TG-rich lipoproteins, thereby contributing to hypertriglyceridemia. In addition, TNF- α can decrease apoE mRNA in rat hepatocytes and consequently reduce the receptor-mediated uptake of TG-rich lipoproteins, which therefore remain longer in the circulation (56).

Besides increasing the concentration of TG-rich VLDL particles, TNF- α may also alter their composition. Accordingly, the VLDL content of sphingolipids has been shown to increase (57). Sphingolipids and sphingolipid-metabolizing enzymes may play important roles in atherogenesis, not only by altering the composition of lipoproteins but also by mediating a number of cellular events, which are

believed to be crucial in the development of the vascular lesions, such as proliferation or cell death (58). In addition, the modified VLDL particle has a decreased clearance and may interact with the LDL receptor on macrophages, enhancing foam cell formation. Thus, the TNF- α -induced changes in TG and VLDL metabolism are the same in both humans and rodents and can be considered to be proatherogenic.

TNF- α and cholesterol metabolism

Besides the modifications that occur in TG metabolism, TNF- α may also interfere with cholesterol metabolic pathways. Whereas TNF- α -induced changes in TG metabolism are similar in all species, the effects on cholesterol metabolism differ between rodents and primates. Whereas the administration of TNF- α in rodents is followed by a delayed increase in serum concentrations of total cholesterol and hepatic cholesterol synthesis (4, 16, 36, 55), nonhuman primates and humans show either no change or a decrease in serum cholesterol and LDL-cholesterol levels (38, 41). The mechanisms underlying this species difference are not known. In primates, TNF- α was indicated to decrease HDL concentrations (41). In addition, the composition of lipoproteins can be altered upon the action of TNF- α . The mechanisms through which TNF- α exerts its effects on cholesterol metabolism are complex and take place at different levels, including the hepatocytes and peripheral cells, such as endothelial cells (Fig. 3).

In rodents, TNF- α may increase hepatic cholesterol synthesis by stimulating the activity of HMG-CoA reductase, the rate-limiting enzyme in the cholesterol biosynthetic pathway (36). The effect is specific, as other enzymes implicated in cholesterol synthesis in the liver are not activated, and is likely to be independent of dietary

regulation (59). Despite a marked increase in HMG-CoA reductase activity, TNF- α produces only a modest increase in hepatic cholesterol synthesis and circulating cholesterol concentrations. This is attributable to an inhibitory effect of TNF- α on the production and activity of squalene synthase (60), the first committed enzyme in cholesterol synthesis located at a branch point in the mevalonate pathway. The enzyme plays an important role in regulating the flux of metabolic intermediates to the sterol pathways. Thus, the effects of TNF- α on the cholesterol biosynthetic pathway are likely to maintain an adequate cholesterol synthesis while redirecting a proportion of the mevalonate metabolites into the nonsteroidal pathways.

In contrast to the situation in rodents, a decrease of 7% in total cholesterol and of 43% in HDL-cholesterol concentrations was observed in cancer patients after administration of recombinant human TNF- α as a 5 day continuous infusion (41). Moreover, plasma cholesterol concentration was shown to be constantly depressed in all types of acute conditions (2–4, 37, 38) that are normally associated with high levels of TNF- α . The cholesterol content was reduced in both LDL and HDL particles. The mechanisms responsible for these effects in humans and primates have not been thoroughly studied using *in vivo* experiments. However, using human hepatoma HepG2 cells, it was shown that TNF- α is capable of decreasing the secretion of apoA-I and apoB in a dose-dependent manner (61). Therefore, the decrease in apolipoprotein secretion might account at least in part for the hypocholesterolemia seen during acute and chronic inflammatory conditions.

Besides the effects on the apolipoprotein synthesis pathway, TNF- α may decrease hepatic cholesterol catabolism and excretion. The elimination of cholesterol from the body is achieved mostly through its conversion into

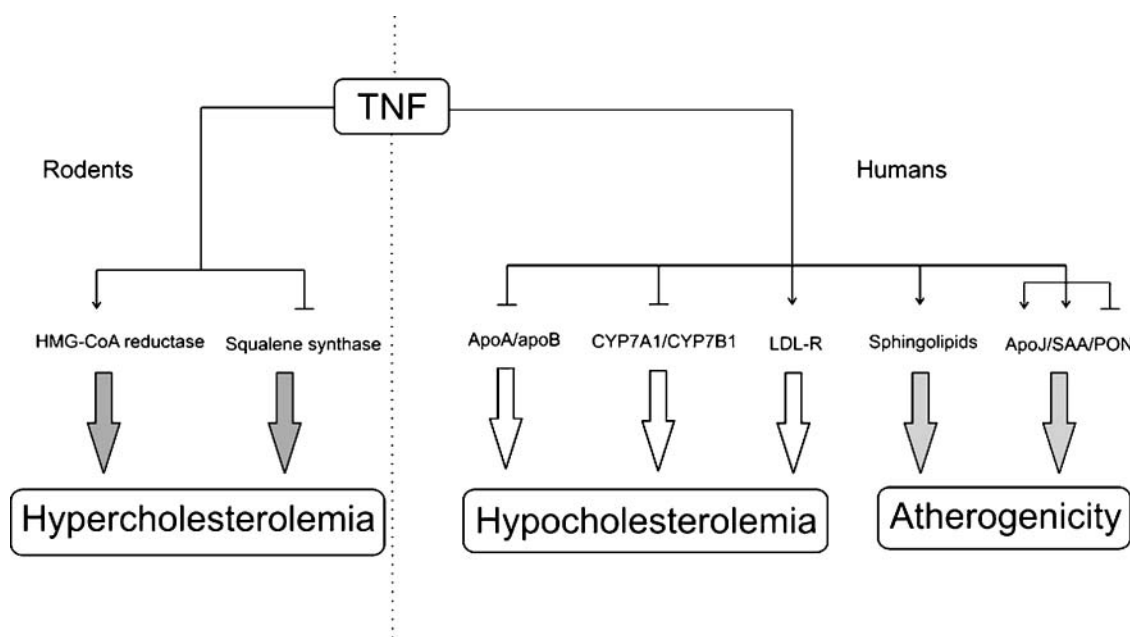

Fig. 3. Effects of TNF- α on cholesterol metabolism in rodents and humans. ApoA, apolipoprotein A; CYP7A1, cholesterol-7 α -hydroxylase; CYP7B1, oxysterol 7 α -hydroxylase; LDL-R, low density lipoprotein receptor; PON, paraoxonase; SAA, serum amyloid A.

bile acids, a pathway regulated by the enzyme cholesterol-7 α -hydroxylase (CYP7A1). Several cytokines, including TNF- α , were shown to inhibit the expression and activity of CYP7A1, the rate-limiting enzyme in the classic pathway of bile acid synthesis (62). The mechanism involves the activation of a mitogen-activated protein kinase-dependent signaling cascade that eventually dampens the hepatic nuclear factor-4-mediated activation of CYP7A1 (62). In addition, the activities of mitochondrial sterol 27-hydroxylase and oxysterol 7 α -hydroxylase, the rate-limiting enzymes in the alternative pathway of bile acid synthesis, were also downregulated by TNF- α and other inflammatory cytokines in experiments using human hepatoma cell lines (63). These data suggest that in both humans and animals, TNF- α limits cholesterol elimination from the body while increasing its availability for other hepatic processes that operate during the acute phase response.

TNF- α can increase LDL binding to HepG2 cells in a dose-responsive manner, paralleled by increased steady-state levels of LDL receptor mRNA (64). Other cytokines, including IFN γ , macrophage-colony-stimulating factor, and granulocyte macrophage-colony-stimulating factor, do not affect LDL binding to such cells (64). This mechanism may increase the clearance of LDL particles from the circulation and therefore contribute to the low cholesterol concentrations in blood observed after TNF- α administration in humans. Despite the decrease in LDL plasma concentrations, TNF- α is likely to induce changes in LDL composition that eventually increase the atherogenicity of this particle. In patients with acquired immunodeficiency syndrome, a decrease in LDL concentrations was associated

with a decrease in particle size, resulting in small dense LDL (65), which is more proatherogenic. Moreover, TNF- α increased the concentration of secretory phospholipase A₂ (66). The secretory phospholipase A₂ hydrolyzes phospholipids in LDL, generating FAs that can further contribute to oxidized LDL formation (67). Finally, the LDL content in sphingolipids, including sphingomyelin and ceramide, is increased (57). All of these changes in LDL composition render the particle more atherogenic.

Reverse cholesterol transport

There are several mechanisms through which HDL protects against atherogenesis. One of the most extensively studied and accepted hypotheses suggests that HDL plays a role in removing excess cholesterol from peripheral cells and returning it to the liver for excretion. This mechanism is called reverse cholesterol transport (RCT) and plays a crucial role in preventing or reversing the development of atherosclerotic lesions (68, 69) (Fig. 4). This process is initiated by the efflux of cholesterol from arterial wall cells onto lipid-poor apoA-I or pre β -HDL particles and is regulated by ABCA1 and ABCG1 (70). Subsequently, LCAT esterifies free cholesterol in HDL, a process that is essential for HDL to efficiently remove cholesterol from cells and tissues, thus contributing to the antiatherogenic properties of HDL. Cholesteryl ester transfer protein (CETP) further transfers cholesteryl esters from HDL to TG-rich lipoproteins, whereas phospholipid transfer protein transfers phospholipids from TG-rich lipoproteins to HDL. Finally, HL hydrolyzes TG and phospholipids in large α -HDL, generating small pre β -HDL particles that begin a

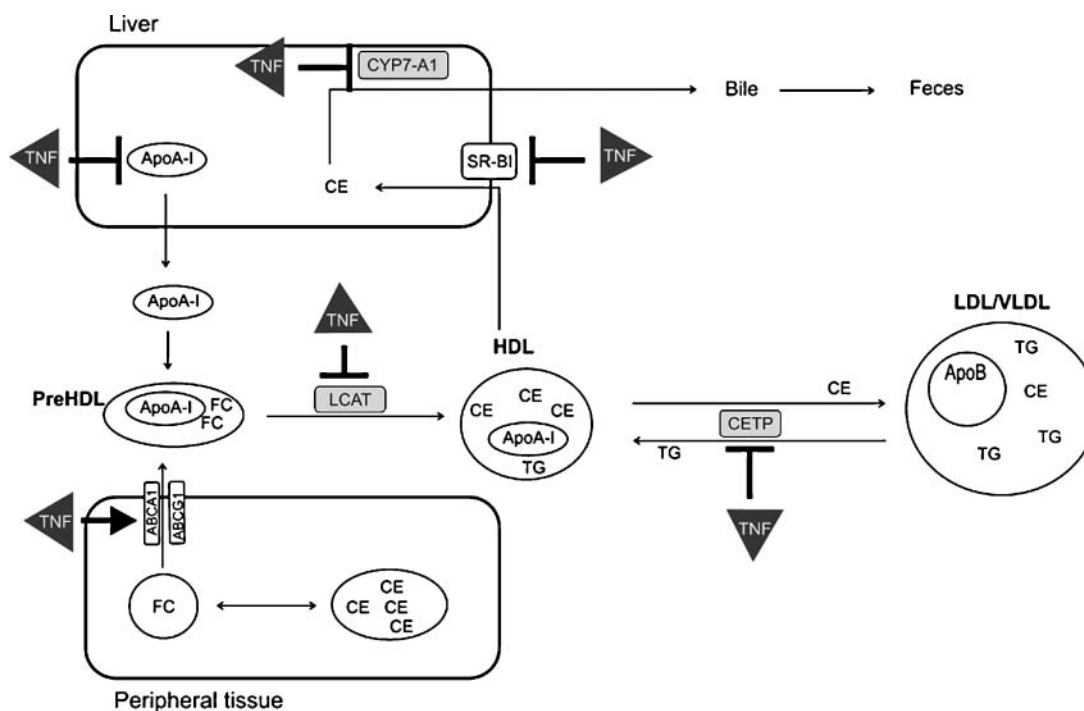

Fig. 4. Reverse cholesterol transport. TNF- α can interfere at several levels with the major mechanism responsible for the removal of cholesteryl esters from peripheral tissues. CE, cholesteryl ester; CETP, cholesteryl ester transfer protein; FC, free cholesterol; SR-BI, scavenger receptor class B type I.

new cycle in the RCT process (68, 69). In addition, scavenger receptor class B type I plays a key role in the selective uptake of cholesteryl ester into hepatocytes (71). TNF- α has been demonstrated to induce a reduction in RCT attributable to multiple changes at each step in this pathway.

The hepatic synthesis and plasma activity of LCAT are decreased by TNF- α in primates (72), resulting in decreased HDL-cholesterol concentrations, similar to what is found in humans or animals with mutations in the LCAT gene (73). This might partly account for the decrease in cholesterol concentrations seen after TNF infusion. CETP activity is decreased upon TNF- α action in rodents (74). Interestingly, Japanese populations with CETP deficiency exhibited high levels of HDL. Given these facts, CETP was recently described as a new therapeutic target, and CETP-blocking agents have been developed to test their potential for increasing HDL and decreasing cardiovascular risk (69, 75–77). TNF- α is also able to decrease scavenger receptor class B type I mRNA in the liver and in Hep3B hepatoma cells, resulting in an impaired cholesterol uptake and excretion (71). Thus, besides reducing hepatic apoA-I, TNF- α is likely to affect the level of cholesterol removal from peripheral cells, transfer between particles, and uptake by the liver. Although an initial decrease of RCT during the acute phase response may be beneficial as it redirects cholesterol toward macrophages for host defense, a prolonged or sustained inflammatory response, as seen in chronic infection and inflammation, may continually impair RCT, thus leading to cholesterol deposition in macrophages and promoting atherosclerosis.

Besides decreasing circulating HDL-cholesterol concentrations, TNF- α may also alter HDL composition. The content of apoJ and apoSAA in HDL increases, whereas that of apoA-I may decrease (4, 78, 79). Serum amyloid A-rich HDL particles are rapidly cleared from the plasma, and thus the increase in serum amyloid A could also contribute to a decrease in HDL concentrations (80). In addition, serum amyloid A-rich HDL has a decreased affinity for hepatocytes and an increased affinity for macrophages, which may result in a redirection of HDL metabolism. Furthermore, the decrease in apoA-I may alter the capacity of pre β -HDL particles to attract cholesterol from peripheral cells in a step that initiates the RCT. Several HDL-associated proteins, including paraoxonase-1, possess antioxidant activities and help HDL to exert its role in protecting LDL against oxidation. On HepG2 cells, TNF- α downregulates the expression of paraoxonase-1, which results in a depletion of HDL antioxidant properties (81). This will eventually convert HDL into a proatherogenic particle, enhancing the atherogenic process. Accordingly, a recent study documented the presence of proinflammatory HDL in patients with systemic lupus erythematosus and RA and suggested that it may serve as a biomarker for atherosclerosis in these chronic inflammatory conditions (82).

Several recent publications have indicated that TNF- α may also exert antiatherogenic effects, for instance through the inhibition of atherosclerotic plaque development. These assumptions are based on the observation

that TNF-RI-deficient mice develop more severe atherosclerotic lesions compared with normal littermates when fed an atherogenic diet (83). In TNF receptor knockout mice, this is attributable to an upregulation of the scavenger receptor on the macrophages followed by an increase of cholesterol uptake and foam cell formation. Interestingly, plasma lipid concentrations did not differ between the strains. Assuming that TNF- α has antiatherogenic properties, Gerbod-Giannone et al. (84) recently indicated that ABCA1, a member of the ABC transporter superfamily, is upregulated by TNF- α in a dose-dependent manner, through a mechanism involving the activation of nuclear factor- κ B. As mentioned previously, ABCA1 plays an important role in the RCT, promoting the efflux of cholesterol from peripheral cells into the lipid-poor apoA-I or pre β -HDL particles. These findings in TNF receptor knockout mice are puzzling because TNF- α gene disruption has been shown to diminish the development of atherosclerosis in apoE-deficient mice (10, 35, 85). However, in another study, loss of TNF- α did not alter the development of lesions in mice fed an atherogenic diet (86). In addition, loss of TNF-RII had no influence on lesion growth in the same mice (86). Together, these data illustrate the complexity of TNF ligand and receptor interactions in the atherogenesis pathways, with disparate actions depending on the targeted cell type, signaling pathways, duration of action, and, in the case of murine experiments, the genetic background of the rodent. In addition, some discrepancies regarding TNF- α actions might be attributable to the fact that the interchangeability of data from whole organisms and cell culture studies may not always be valid. The implication of other undefined members of the TNF ligand or receptor signaling pathways in regulating atherogenesis could not be excluded. To conclude, TNF- α has dissimilar effects on cholesterol levels in rodents and humans, with inhibitory actions on apoA-I hepatic synthesis and cholesterol reverse transport in humans.

TNF- α blockade and lipid metabolism

The effects of TNF- α blockade on the circulating lipid pattern were recently explored in patients with chronic inflammatory conditions and increased TNF- α plasma concentrations. We evaluated the influence of short-term therapy with adalimumab, a fully human anti-TNF monoclonal antibody, on the lipoprotein profile and on markers of inflammation in 33 patients with active RA. Plasma HDL-cholesterol concentrations increased significantly at 2 weeks after the start of therapy by an average of 0.12 mmol/l, whereas no differences were seen in the placebo-treated group. In addition, the atherogenic index decreased (87). Our results were later confirmed in another study in a larger RA group, indicating that infliximab, a chimeric anti-TNF monoclonal antibody, increases plasma HDL-cholesterol concentrations by \sim 0.10 mmol/l after 2 weeks of therapy and that the effect is still sustained after 6 weeks of therapy (88). Although short-term effects of anti-TNF agents on lipoproteins are likely to increase HDL-cholesterol and decrease the ath-

erogenic index, the immediate effects seem to yield opposite results. One study, investigating the effects of infliximab on plasma lipoprotein concentrations at 24 h after each infusion, showed that total cholesterol, HDL-cholesterol, and apoA-I levels decreased significantly, whereas the atherogenic index increased on the day after infusion. However, between infusions, a slight increase in HDL-cholesterol concentrations and a decrease in the atherogenic index after 2 and 6 weeks of therapy were observed compared with baseline (89). Whether the nonatherogenic lipid profile persists and indeed results in less atherogenesis in the long term is the subject of future studies.

TNF- α AND GLUCOSE METABOLISM

The development of the concept that type 2 DM is an inflammatory condition is an exciting and novel approach to the understanding of this condition. Recent work in the area of obesity has confirmed that obesity is a state of low-grade chronic inflammation, as indicated by the increased concentrations of C-reactive protein, IL-6, and other inflammatory markers identified in the plasma of obese individuals (11, 90). This concept has raised the possibility that type 2 DM, another closely related insulin-resistant state, might be also an inflammatory condition. Indeed, proinflammatory cytokines (TNF- α , IL-18, IL-6) and sialic acid were found to be increased in patients with type 2 DM (91, 92). Moreover, inflammatory markers such as C-reactive protein and IL-6 are even likely to predict the development of type 2 diabetes in white nonsmoking adults (93). There are now ample data to regard inflammation as a link between insulin resistance, obesity, and diabetes.

Among inflammatory markers, TNF- α was first demonstrated to be involved in the pathogenesis of insulin resistance. In 1993, Hotamisligil, Shargill, and Spiegelman (17) published the first evidence of constitutive TNF- α expression in adipocytes and further demonstrated that adipocytes from obese animals (*ob/ob* mouse, *db/db* mouse, and *fa/fa* Zucker rat) express markedly increased amounts of TNF- α . In addition, neutralization of TNF- α using soluble receptors was followed by an improvement of the insulin sensitivity in these animals. Later data have shown that TNF- α is also expressed in human adipose tissue and that its plasma concentration in obese subjects is decreased after weight loss (94, 95). In addition, there is a significant positive correlation between the changes in circulating TNF- α concentrations and body mass index. Adipocyte-derived TNF- α is thought to function predominantly in an autocrine/paracrine manner in adipose tissue and has been postulated to play a crucial role in the development of insulin resistance and glucose metabolism abnormalities that link obesity to type 2 DM (11, 96).

Indeed, TNF- α - and TNF-RI-deficient mice have lower body weights than wild-type mice and their sensitivity to insulin is increased; they are protected against obesity-induced insulin resistance (97, 98). In vitro studies on human cell lines have confirmed that when exposed to TNF- α , adipocytes become insulin-resistant (12). In ad-

dition, human skeletal muscle cells overexpress TNF- α , which may contribute to the development of a generalized insulin-resistant state during inflammation (99). In contrast to TNF-induced changes in lipid metabolism, there are no significant differences between mice and humans regarding TNF's effects on insulin sensitivity. Several mechanisms have been proposed to explain how TNF- α induces the insulin resistance in adipocytes as well as systemically (Fig. 5). First, TNF- α has the ability to inhibit the insulin-stimulated tyrosine kinase activity of the insulin receptor and the insulin receptor substrate-1 (IRS-1) by inducing a serine phosphorylation of IRS-1 and thus converting IRS-1 into an inhibitor of the insulin receptor tyrosine kinase in vitro (12). This effect is mediated mainly via TNF-RI (29–31) and involves the activation of the inhibitor κ B kinase- β (100). Second, TNF- α stimulates lipolysis in the adipose tissue, thus increasing the plasma concentration of the FFA that eventually contributes to the development of the insulin-resistant phenotype (42). Accordingly, hepatic glucose production increases and glucose uptake and metabolism in the muscles decrease. In adipocytes, TNF- α downregulates the expression of several proteins implicated in the insulin receptor pathway, including IRS-1, glucose transporter 4, peroxisome proliferator-activated receptor γ , and adiponectin (12, 101–103). In particular, adiponectin plays an important role in the mechanisms that maintain the sensitivity to insulin, and its plasma concentration is inversely related to the degree of insulin resistance (104). Moreover, TNF- α upregulates the production of leptin, which is known to regulate energy homeostasis, to reduce pancreatic insulin secretion, and to promote insulin resistance (105). Therefore, TNF- α may also contribute indirectly to an insulin-resistant state by inhibiting adiponectin and by stimulating leptin actions on the glucose metabolic pathways. In addition, monocyte chemotactic protein-1 expression and production can be stimulated by TNF- α (106), increasing the recruitment of macrophages into the adipose tissue, which will augment the inflammatory state and trigger resistance to insulin.

Pathological situations associated with high TNF- α production, such as endotoxemia, cancer, and trauma, were indicated to present a state of peripheral insulin resistance. The administration of TNF- α to healthy humans was reported to reduce insulin sensitivity, inducing hyperglycemia without decreasing insulin levels (107). In humans, the presence of a promoter polymorphism of TNF- α (G-308A) is associated with increased plasma TNF- α concentrations and a 1.8-fold higher risk of developing diabetes compared with noncarriers (108).

Finally, considerable attention is now focused on the mechanisms by which TNF induces resistance in the cascade of insulin signal transduction and on the possibility that interference with this pathway could be a new therapeutic approach to abrogate insulin resistance and obesity-induced diabetes. Although therapy with soluble TNF- α receptors in diabetic insulin-resistant patients failed to prove its hypothesized beneficial effect (109, 110), several recent reports support a favorable action of anti-TNF- α antibodies on insulin sensitivity (111, 112).

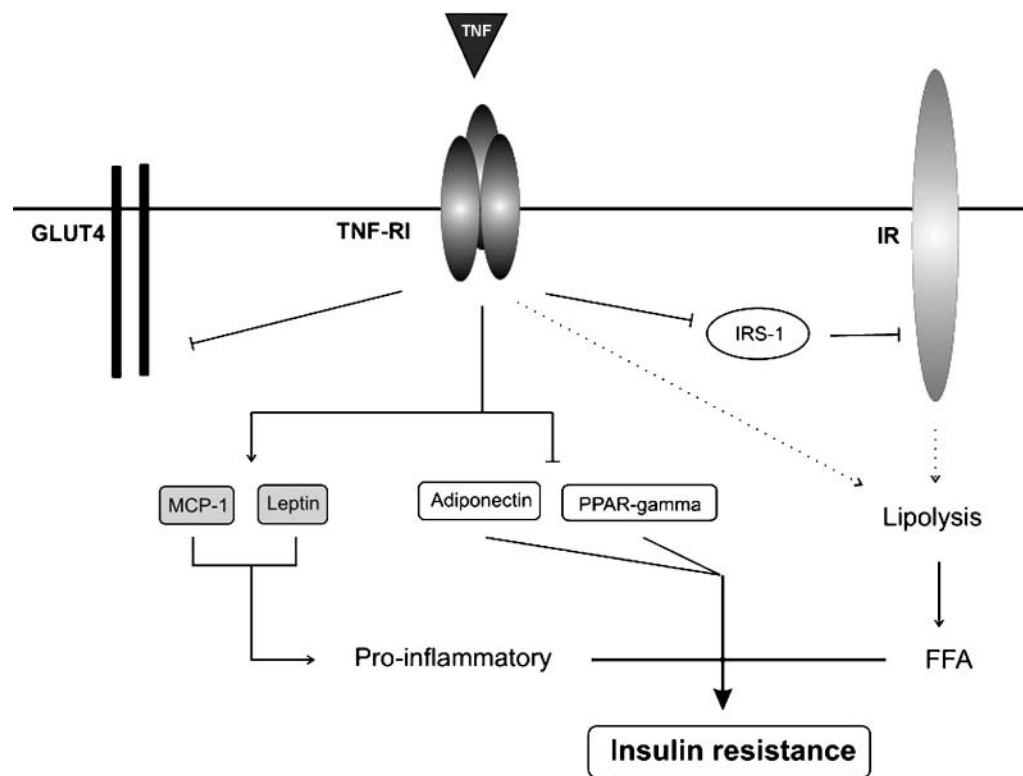

Fig. 5. Mechanisms used by TNF- α to exert its effects on glucose metabolic pathways. GLUT4, glucose transporter 4; IR, insulin receptor; IRS-1, insulin receptor substrate-1; MCP-1, monocyte chemoattractant protein-1; PPAR, peroxisome proliferator-activated receptor; TNF-RI, TNF- α receptor type I.

CONCLUDING REMARKS

Inflammation plays a pivotal role in the development of metabolic syndrome features, including dyslipidemia and altered glucose tolerance. These metabolic changes constitute the substrate for the subsequent development of atherosclerotic plaque and insulin resistance. Among inflammatory markers, TNF- α seems to be a crucial element in the pathogenesis of these conditions. Although lipid changes are beneficial to the host in the case of acute circulatory TNF- α -increasing conditions, prolonged TNF-induced lipid modifications will increase cardiovascular risk and subsequent morbidity and mortality. In this light, chronic inflammation in general and TNF- α in particular are likely to represent the driving force connecting RA, atherosclerosis, and the impaired insulin sensitivity that may occur simultaneously in an individual. First, TNF- α plays a key role in the pathogenesis of RA, as we know from the pharmacological effects of TNF- α -blocking agents in the therapy of RA (19, 20). Second, TNF- α , as part of the inflammatory cascade, plays a crucial role in the development of atherosclerotic lesions (10, 35, 85). In addition, TNF- α is able to induce proatherogenic lipoprotein changes. Finally, TNF- α , by decreasing insulin sensitivity, contributes to the development of glucose metabolism disturbances (17, 94, 98).

Given these facts, TNF- α might emerge as a therapeutic target to combat the development and progression of metabolic syndrome features, at least in RA and other chronic

inflammatory conditions. Indeed, an anti-inflammatory therapy seems reasonable in the case of patients displaying markers of the metabolic syndrome, because statins and peroxisome proliferator-activated receptor γ agonists have been proven to improve lipid and glucose metabolic parameters using anti-inflammatory mechanisms (113, 114). Several studies have explored the effectiveness of TNF- α blockade in combating different features of the metabolic syndrome, but the results obtained are not yet substantial (87–89, 109–112). However, given the increasing incidence of metabolic disturbances and their associated pathology, especially in developed countries, studies that further explore the feasibility of a TNF- α blocker in these pathologic conditions, either as monotherapy or in combination with other drugs, are warranted. [115](#)

The authors thank Dr. Matthew McCall for his important contribution in editing the manuscript. M.G.N. was supported by a VIDI grant from the Netherlands Organization for Scientific Research.

REFERENCES

- Zachary, T., and M. D. Bloomgarden. 2005. 2nd International Symposium on Triglycerides and HDL: metabolic syndrome. *Diabetes Care*. **28**: 2577–2584.
- Wolfe, R. R., J. H. Shaw, and M. J. Durkot. 1983. Energy metabolism in trauma and sepsis: the role of fat. *Prog. Clin. Biol. Res.* **111**: 89–109.

3. Douglas, R. G., and J. H. Shaw. 1989. Metabolic response to sepsis and trauma. *Br. J. Surg.* **76**: 115–122.
4. Feingold, K. R., I. Hardardottir, and C. Grunfeld. 1998. Beneficial effects of cytokine induced hyperlipidemia. *Z. Ernahrungswiss.* **37 (Suppl. 1)**: 66–74.
5. Butler, S. O., I. F. Btaiche, and C. Alaniz. 2005. Relationship between hyperglycemia and infection in critically ill patients. *Pharmacotherapy.* **25**: 963–976.
6. Koltai, M., E. Minker, and A. Ottlecz. 1972. Inhibition of acute inflammation by hyperlipemia. *Experientia.* **28**: 302–303.
7. Park, Y. B., S. K. Lee, W. K. Lee, C. H. Suh, C. W. Lee, C. H. Lee, C. H. Song, and J. Lee. 1999. Lipid profiles in untreated patients with rheumatoid arthritis. *J. Rheumatol.* **26**: 1701–1704.
8. Svenson, K. L., G. Lundqvist, L. Wide, and R. Hallgren. 1987. Impaired glucose handling in active rheumatoid arthritis: relationship to the secretion of insulin and counter-regulatory hormones. *Metabolism.* **36**: 940–943.
9. Dandona, P., A. Aljada, A. Chaudhuri, P. Mohanty, and R. Garg. 2005. Metabolic syndrome: a comprehensive perspective based on interactions between obesity, diabetes, and inflammation. *Circulation.* **111**: 1448–1454.
10. Ross, R. 1999. Atherosclerosis—an inflammatory disease. *N. Engl. J. Med.* **340**: 115–126.
11. Gimeno, R. E., and L. D. Klamann. 2005. Adipose tissue as an active endocrine organ: recent advances. *Curr. Opin. Pharmacol.* **5**: 122–128.
12. Hotamisligil, G. S., D. L. Murray, L. N. Choy, and B. M. Spiegelman. 1994. Tumor necrosis factor alpha inhibits signaling from the insulin receptor. *Proc. Natl. Acad. Sci. USA.* **91**: 4854–4858.
13. Ridker, P. M. 2003. Clinical application of C-reactive protein for cardiovascular disease detection and prevention. *Circulation.* **107**: 363–369.
14. Ridker, P. M., C. H. Hennekens, J. E. Buring, and N. Rifai. 2000. C-reactive protein and other markers of inflammation in the prediction of cardiovascular disease in women. *N. Engl. J. Med.* **342**: 836–843.
15. Beutler, B., and A. Cerami. 1986. Cachectin and tumour necrosis factor as two sides of the same biological coin. *Nature.* **320**: 584–588.
16. Grunfeld, C., and K. R. Feingold. 1991. Tumour necrosis factor, cytokines and the hyperlipidemia of infection. *Trends Endocrinol. Metab.* **2**: 213–219.
17. Hotamisligil, G. S., N. S. Shargill, and B. M. Spiegelman. 1993. Adipose expression of tumor necrosis factor-alpha: direct role in obesity-linked insulin resistance. *Science.* **259**: 87–91.
18. Reinhart, K., and W. Karzai. 2001. Anti-tumor necrosis factor therapy in sepsis: update on clinical trials and lessons learned. *Crit. Care Med.* **29 (Suppl. 7)**: 121–125.
19. Lipsky, P. E., D. M. van der Heijde, E. W. St. Clair, D. E. Furst, F. C. Breedveld, J. R. Kalden, J. S. Smolen, M. Weisman, P. Emery, M. Feldmann, et al. 2000. Infliximab and methotrexate in the treatment of rheumatoid arthritis. Anti-Tumor Necrosis Factor Trial in Rheumatoid Arthritis with Concomitant Therapy Study Group. *N. Engl. J. Med.* **343**: 1594–1602.
20. Barrera, P., A. van der Maas, A. E. van Ede, B. A. Kiemeny, R. F. Laan, L. B. van de Putte, and P. L. van Riel. 2002. Drug survival, efficacy and toxicity of monotherapy with a fully human anti-tumor necrosis factor-alpha antibody compared with methotrexate in long-standing rheumatoid arthritis. *Rheumatology (Oxford).* **41**: 430–439.
21. Berbee, J. F., L. M. Havekes, and P. C. Rensen. 2005. Apolipoproteins modulate the inflammatory response to lipopolysaccharide. *J. Endotoxin Res.* **11**: 97–103.
22. Netea, M. G., P. N. M. Demacker, B. J. Kullberg, O. C. Boerman, I. Verschueren, A. F. H. Stalenhoef, and J. W. M. van der Meer. 1996. Low-density lipoprotein receptor-deficient mice are protected against lethal endotoxemia and severe Gram-negative infections. *J. Clin. Invest.* **97**: 1366–1372.
23. Netea, M. G., P. N. M. Demacker, B. J. Kullberg, L. E. H. Jacobs, T. J. G. Verver-Jansen, O. C. Boerman, A. F. H. Stalenhoef, and J. W. M. van der Meer. 1998. Bacterial lipopolysaccharide binds and stimulates cytokine-producing cells before neutralization by endogenous lipoproteins can occur. *Cytokine.* **10**: 766–772.
24. Van Doornum, S., G. McColl, and I. P. Wicks. 2002. Accelerated atherosclerosis: an extraarticular feature of rheumatoid arthritis? *Arthritis Rheum.* **46**: 862–873.
25. Svenungsson, E., I. Gunnarsson, G. Z. Fei, I. E. Lundberg, L. Klareskog, and J. Frostegard. 2003. Elevated triglycerides and low levels of high-density lipoprotein as markers of disease activity in association with up-regulation of the tumor necrosis factor alpha/tumor necrosis factor receptor system in systemic lupus erythematosus. *Arthritis Rheum.* **48**: 2533–2540.
26. Jara, L. J., G. Medina, O. Vera-Lastra, and M. C. Amigo. 2006. Accelerated atherosclerosis, immune response and autoimmune rheumatic diseases. *Autoimmun. Rev.* **5**: 195–201.
27. Boers, M., B. Dijkmans, S. Gabriel, H. Maradit-Kremers, J. O'Dell, and T. Pincus. 2004. Making an impact on mortality in rheumatoid arthritis: targeting cardiovascular comorbidity. *Arthritis Rheum.* **50**: 1734–1739.
28. Aggarwal, B. B. 2003. Signalling pathways of the TNF superfamily: a double-edged sword. *Nat. Rev. Immunol.* **3**: 745–756.
29. Peraldi, P., G. S. Hotamisligil, W. A. Buurman, M. F. White, and B. M. Spiegelman. 1996. Tumor necrosis factor (TNF)-alpha inhibits insulin signaling through stimulation of the p55 TNF receptor and activation of sphingomyelinase. *J. Biol. Chem.* **271**: 13018–13022.
30. Liu, L. S., M. Spelleken, K. Rohring, H. Hauner, and J. Eckel. 1998. Tumor necrosis factor-alpha acutely inhibits insulin signaling in human adipocytes: implication of the p80 tumor necrosis factor receptor. *Diabetes.* **47**: 515–522.
31. Uysal, K. T., S. M. Wiesbrock, and G. S. Hotamisligil. 1998. Functional analysis of tumor necrosis factor (TNF) receptors in TNF-alpha-mediated insulin resistance in genetic obesity. *Endocrinology.* **139**: 4832–4838.
32. Sethi, J. K., H. Xu, K. T. Uysal, S. M. Wiesbrock, L. Scheja, and G. S. Hotamisligil. 2000. Characterisation of receptor-specific TNF-alpha functions in adipocyte cell lines lacking type 1 and 2 TNF receptors. *FEBS Lett.* **469**: 77–82.
33. Hotamisligil, G. S., P. Arner, R. L. Atkinson, and B. M. Spiegelman. 1997. Differential regulation of the p80 tumor necrosis factor receptor in human obesity and insulin resistance. *Diabetes.* **46**: 451–455.
34. Blann, A. D., and C. N. McCullum. 1998. Increased levels of soluble tumor necrosis factor receptors in atherosclerosis: no clear relationship with levels of tumor necrosis factor. *Inflammation.* **22**: 483–491.
35. Skoog, T., W. Dichtl, S. Boquist, C. Skoglund-Andersson, F. Carpe, R. Tang, M. G. Bond, U. de Faire, J. Nilsson, P. Eriksson, et al. 2002. Plasma tumour necrosis factor-alpha and early carotid atherosclerosis in healthy middle-aged men. *Eur. Heart J.* **23**: 376–383.
36. Memon, R. A., C. Grunfeld, A. H. Moser, and K. R. Feingold. 1993. Tumor necrosis factor mediates the effects of endotoxin on cholesterol and triglyceride metabolism in mice. *Endocrinology.* **132**: 2246–2253.
37. Lind, L., and H. Lithell. 1994. Impaired glucose and lipid metabolism seen in intensive care patients is related to severity of illness and survival. *Clin. Intensive Care.* **5**: 100–105.
38. Gabay, C., and I. Kushner. 1999. Acute-phase proteins and other systemic responses to inflammation. *N. Engl. J. Med.* **340**: 448–454.
39. Rossi Fanelli, F., C. Cangiano, M. Muscaritoli, L. Conversano, G. F. Torelli, and A. Cascino. 1995. Tumor-induced changes in host metabolism: a possible marker of neoplastic disease. *Nutrition.* **11**: 595–600.
40. Grunfeld, C., M. Pang, W. Doerrler, J. K. Shigenaga, P. Jensen, and K. R. Feingold. 1992. Lipids, lipoproteins, triglyceride clearance, and cytokines in human immunodeficiency virus infection and the acquired immunodeficiency syndrome. *J. Clin. Endocrinol. Metab.* **74**: 1045–1052.
41. Sherman, M. L., D. R. Spriggs, K. A. Arthur, K. Imamura, E. Frei III, and D. W. Kufe. 1988. Recombinant human tumor necrosis factor administered as a five-day continuous infusion in cancer patients: phase I toxicity and effects on lipid metabolism. *J. Clin. Oncol.* **6**: 344–350.
42. Feingold, K. R., M. Marshall, R. Gulli, A. H. Moser, and C. Grunfeld. 1994. Effect of endotoxin and cytokines on lipoprotein lipase activity in mice. *Arterioscler. Thromb.* **14**: 1866–1872.
43. Feingold, K. R., S. Adi, I. Stapsler, A. H. Moser, R. Neese, J. A. Verdier, W. Doerrler, and C. Grunfeld. 1990. Diet affects the mechanisms by which TNF stimulates hepatic triglyceride production. *Am. J. Physiol.* **259**: E59–E64.
44. Ryden, M., A. Dicker, V. van Harmelen, H. Hauner, M. Brunnberg, L. Perbeck, F. Lonnqvist, and P. Arner. 2002. Mapping of early signaling events in tumor necrosis factor-alpha-mediated lipolysis in human fat cells. *J. Biol. Chem.* **277**: 1085–1091.

45. Londos, C., D. L. Brasaemle, C. Z. Schultz, D. C. Adler-Wailes, D. M. Levin, A. R. Kimmel, and C. M. Rondinone. 1999. On the control of lipolysis in adipocytes. *Ann. N. Y. Acad. Sci.* **892**: 155–168.
46. Souza, S. C., L. M. de Vargas, M. T. Yamamoto, P. Lien, M. D. Franciosa, L. G. Moss, and A. S. Greenberg. 1998. Overexpression of perilipin A and B blocks the ability of tumor necrosis factor alpha to increase lipolysis in 3T3-L1 adipocytes. *J. Biol. Chem.* **273**: 24665–24669.
47. Zimmermann, R., J. G. Strauss, G. Haemmerle, G. Schoiswhol, R. Birner-Gruenberger, M. Riederer, A. Lass, G. Neuberger, F. Eisenhaber, A. Hermetter, et al. 2004. Fat mobilization in adipose tissue is promoted by adipose triglyceride lipase. *Science*. **306**: 1383–1386.
48. Sumida, M., K. Sekiya, H. Okuda, Y. Tanaka, and T. Shiosaka. 1990. Inhibitory effect of tumor necrosis factor on gene expression of hormone sensitive lipase in 3T3-L1 adipocytes. *J. Biochem. (Tokyo)*. **107**: 1–2.
49. Kralisch, S., J. Klein, U. Lossner, M. Bluher, R. Paschke, M. Stunvoll, and M. Fasshauer. 2005. Isoproterenol, TNF-alpha, and insulin downregulate adipose triglyceride lipase in 3T3-L1 adipocytes. *Mol. Cell. Endocrinol.* **240**: 43–49.
50. Green, A., S. B. Dobias, D. J. Walters, and A. R. Brasier. 1994. Tumor necrosis factor increases the rate of lipolysis in primary cultures of adipocytes without altering levels of hormone-sensitive lipase. *Endocrinology*. **134**: 2581–2588.
51. Gual, P., Y. Le Marchand-Brustel, and J. F. Tanti. 2005. Positive and negative regulation of insulin signalling through IRS-1 phosphorylation. *Biochimie*. **87**: 99–109.
52. Gasic, S., B. Tian, and A. Green. 1999. Tumor necrosis factor alpha stimulates lipolysis in adipocytes by decreasing Gi protein concentrations. *J. Biol. Chem.* **274**: 6770–6775.
53. Ryden, M., E. Arvidsson, L. Blomqvist, L. Perbeck, A. Dicker, and P. Arner. 2004. Targets for TNF-alpha-induced lipolysis in human adipocytes. *Biochem. Biophys. Res. Commun.* **318**: 168–175.
54. Grunfeld, C., J. A. Verdier, R. Neese, A. H. Moser, and K. R. Feingold. 1988. Mechanisms by which tumor necrosis factor stimulates hepatic fatty acid synthesis in vivo. *J. Lipid Res.* **29**: 1327–1335.
55. Grunfeld, C., M. Soued, S. Adi, A. H. Moser, C. A. Dinarello, and K. R. Feingold. 1990. Evidence for two classes of cytokines that stimulate hepatic lipogenesis: relationships among tumor necrosis factor, interleukin-1 and interferon-alpha. *Endocrinology*. **127**: 46–54.
56. Tripp, R. J., A. Tabares, H. Wang, and S. Lanza-Jacoby. 1993. Altered hepatic production of apolipoproteins B and E in the fasted septic rat: factors in the development of hypertriglyceridemia. *J. Surg. Res.* **55**: 465–472.
57. Memon, R. A., W. M. Holleran, A. H. Moser, T. Seki, Y. Uchida, J. Fuller, J. K. Shigenaga, C. Grunfeld, and K. R. Feingold. 1998. Endotoxin and cytokines increase hepatic sphingolipid biosynthesis and produce lipoproteins enriched in ceramides and sphingomyelin. *Arterioscler. Thromb. Vasc. Biol.* **18**: 1257–1265.
58. Auge, N., A. Negre-Salvayre, R. Salvayre, and T. Levade. 2000. Sphingomyelin metabolites in vascular cell signaling and atherogenesis. *Prog. Lipid Res.* **39**: 207–229.
59. Feingold, K. R., A. S. Pollock, A. H. Moser, J. K. Shigenaga, and C. Grunfeld. 1995. Discordant regulation of proteins of cholesterol metabolism during the acute phase response. *J. Lipid Res.* **36**: 1474–1482.
60. Memon, R. A., I. Shechter, A. H. Moser, J. K. Shigenaga, C. Grunfeld, and K. R. Feingold. 1997. Endotoxin, tumor necrosis factor, and interleukin-1 decrease hepatic squalene synthase activity, protein, and mRNA levels in Syrian hamsters. *J. Lipid Res.* **38**: 1620–1629.
61. Ettinger, W. H., V. K. Varna, M. Sorci-Thomas, J. S. Parks, R. C. Sigmon, T. K. Smith, and R. B. Verdery. 1994. Cytokines decrease apolipoprotein accumulation in medium from Hep G2 cells. *Arterioscler. Thromb.* **14**: 8–13.
62. De Fabiani, E., N. Mitro, A. C. Anzulovich, A. Pinelli, G. Galli, and M. Crestani. 2001. The negative effects of bile acids and tumor necrosis factor- α on the transcription of cholesterol 7 α -hydroxylase gene (CYP7A1) converge to hepatic nuclear factor-4. *J. Biol. Chem.* **276**: 30708–30716.
63. Memon, R. A., A. H. Moser, J. K. Shigenaga, C. Grunfeld, and K. R. Feingold. 2001. In vivo and in vitro regulation of sterol 27-hydroxylase in the liver during the acute phase response. Potential role of hepatocyte nuclear factor-1. *J. Biol. Chem.* **276**: 30118–30126.
64. Stopeck, A. T., A. C. Nicholson, F. P. Mancini, and D. P. Hajjar. 1993. Cytokine regulation of low density lipoprotein receptor gene transcription in HepG2 cells. *J. Biol. Chem.* **268**: 17489–17494.
65. Feingold, K. R., R. M. Krauss, M. Pang, W. Doerrler, P. Jensen, and C. Grunfeld. 1993. The hypertriglyceridemia of acquired immunodeficiency syndrome is associated with an increased prevalence of low density lipoprotein subclass pattern B. *J. Clin. Endocrinol. Metab.* **76**: 1423–1427.
66. Arbibe, L., D. Vial, I. Rosinski-Chupin, N. Havet, M. Huerre, B. B. Vargaftig, and L. Tourqui. 1997. Endotoxin induces expression of type II phospholipase A2 in macrophages during acute lung injury in guinea pigs. *J. Immunol.* **159**: 391–400.
67. Pruzanski, W., P. Vadas, and J. Browning. 1993. Secretory pancreatic group II phospholipase A2: role in physiologic and inflammatory processes. *J. Lipid Mediat.* **8**: 161–167.
68. Ohashi, R., H. Mu, X. Wang, Q. Yao, and C. Chen. 2005. Reverse cholesterol transport and cholesterol efflux in atherosclerosis. *Q. J. Med.* **98**: 845–856.
69. Linsel-Nitschke, P., and A. R. Tall. 2005. HDL as a target in the treatment of atherosclerotic cardiovascular disease. *Nat. Rev. Drug Discov.* **4**: 193–205.
70. Duffy, D., and D. J. Rader. 2006. Emerging therapies targeting high-density lipoprotein metabolism and reverse cholesterol transport. *Circulation*. **113**: 1140–1150.
71. Khovidhunkit, W., A. H. Moser, J. K. Shigenaga, C. Grunfeld, and K. R. Feingold. 2001. Regulation of scavenger receptor class B type I in master liver and Hep3B cells by endotoxin and cytokines. *J. Lipid Res.* **42**: 1636–1644.
72. Ettinger, W. H., L. D. Miller, J. J. Albers, T. K. Smiths, and J. S. Parks. 1990. Lipopolysaccharide and tumor necrosis factor cause a fall in plasma concentration of lecithin:cholesterol acyltransferase in cynomolgus monkeys. *J. Lipid Res.* **31**: 1099–1107.
73. Kuivenhoven, J. A., H. Pritchard, J. Hill, J. Frochlich, G. Assmann, and J. Kastelein. 1997. The molecular pathology of lecithin:cholesterol acyltransferase (LCAT) deficiency syndromes. *J. Lipid Res.* **38**: 191–205.
74. Hardardottir, I., A. H. Moser, J. Fuller, C. Fielding, K. R. Feingold, and C. Grunfeld. 1996. Endotoxin and cytokines decrease serum levels and extra hepatic protein and mRNA levels of cholesteryl ester transfer protein in Syrian hamsters. *J. Clin. Invest.* **97**: 2585–2592.
75. Inazu, A., M. L. Brown, C. B. Hesler, L. B. Agellon, J. Koizumi, K. Takata, Y. Maruhama, H. Mabuchi, and A. R. Tall. 1990. Increased high-density lipoprotein levels caused by a common cholesteryl-ester transfer protein gene mutation. *N. Engl. J. Med.* **323**: 1234–1238.
76. Brousseau, M. E., E. J. Schaefer, M. L. Wolfe, L. T. Bloedon, A. G. Digenio, R. W. Clark, J. P. Mancuso, and D. J. Rader. 2004. Effects of an inhibitor of cholesteryl ester transfer protein on HDL cholesterol. *N. Engl. J. Med.* **350**: 1505–1515.
77. de Grooth, G. J., J. A. Kuivenhoven, A. F. Stalenhoef, J. de Graaf, A. H. Zwinderman, J. L. Pasma, A. van Tol, and J. J. Kastelein. 2002. Efficacy and safety of a novel cholesteryl ester transfer protein inhibitor, JTT-705, in humans: a randomized phase II dose-response study. *Circulation*. **105**: 2159–2165.
78. Hardardottir, I., S. T. Kunitake, A. H. Moser, W. Doerrler, J. H. Rapp, C. Grunfeld, and K. R. Feingold. 1994. Endotoxin and cytokines increase hepatic mRNA levels and serum concentrations of apolipoprotein J (clusterin) in Syrian hamsters. *J. Clin. Invest.* **94**: 1304–1309.
79. Hardardottir, I., A. H. Moser, R. Memon, C. Grunfeld, and K. R. Feingold. 1994. Effects of TNF, IL-1, and the combination of both cytokines on cholesterol metabolism in Syrian hamsters. *Lymphokine Cytokine Res.* **13**: 161–166.
80. Hoffman, G. S., and E. P. Benditt. 1983. Plasma clearance kinetics of the amyloid-related high density lipoprotein apoprotein, serum amyloid protein (apoSAA), in the mouse. Evidence for rapid apoSAA clearance. *J. Clin. Invest.* **71**: 926–934.
81. Kumon, Y., Y. Nakauchi, T. Suehiro, T. Shiinoki, N. Tanimoto, M. Inoue, T. Nakamura, K. Hashimoto, and J. D. Sipe. 2002. Pro-inflammatory cytokines but not acute phase serum amyloid A or C-reactive protein, downregulate paraoxonase 1 (PON1) expression by HepG2 cells. *Amyloid*. **9**: 160–164.
82. McMahon, M., J. Grossman, J. FitzGerald, E. Dahlin-Lee, D. J. Wallace, B. Y. Thong, H. Badsha, K. Kalunian, C. Charles, M. Navab, et al. 2006. Proinflammatory high-density lipoprotein as a biomarker for atherosclerosis in patients with systemic lupus

- erythematous and rheumatoid arthritis. *Arthritis Rheum.* **54**: 2541–2549.
83. Schreyer, S. A., J. J. Peschon, and R. C. Le Boeuf. 1996. Accelerated atherosclerosis in mice lacking tumor necrosis factor receptor p55. *J. Biol. Chem.* **271**: 26174–26178.
84. Gerbod-Giannone, M. C., Y. Li, A. Holleboom, S. Han, L. C. Hsu, I. Tabas, and A. R. Tall. 2006. TNF- α induces ABCA1 through NF- κ B in macrophages and in phagocytes ingesting apoptotic cells. *Proc. Natl. Acad. Sci. USA.* **103**: 3112–3117.
85. Ohta, H., H. Wada, T. Niwa, H. Kirii, N. Iwamoto, H. Fujii, K. Saito, K. Sekikawa, and M. Seishima. 2005. Disruption of tumor necrosis factor- α gene diminishes the development of atherosclerosis in apoE-deficient mice. *Atherosclerosis.* **180**: 11–17.
86. Schreyer, S. A., C. M. Vick, and R. C. LeBoeuf. 2002. Loss of lymphotoxin- α but not tumor necrosis factor- α reduces atherosclerosis in mice. *J. Biol. Chem.* **277**: 12364–12368.
87. Popa, C., M. G. Netea, T. Radstake, J. W. Van der Meer, A. F. Stalenhoef, P. L. van Riel, and P. Barrera. 2005. Influence of anti-tumor necrosis factor therapy on cardiovascular risk factors in patients with active rheumatoid arthritis. *Ann. Rheum. Dis.* **64**: 303–305.
88. Vis, M., M. T. Nurmohamed, G. Wolbink, A. E. Voskuyl, M. de Koning, R. J. van de Stadt, J. W. R. Twisk, B. A. C. Dijkmans, and W. F. Lems. 2005. Short term effects of infliximab on the lipid profile in patients with rheumatoid arthritis. *J. Rheumatol.* **32**: 252–255.
89. Irace, C., G. Mancuso, E. Fiaschi, A. Madia, G. Sesti, and A. Gnasso. 2004. Effect of anti TNF- α therapy on arterial diameter and wall shear stress and HDL cholesterol. *Atherosclerosis.* **177**: 113–118.
90. Yudkin, J. S., C. D. Stehouwer, J. J. Emeis, and S. W. Coppack. 1999. C-reactive protein in healthy subjects: associations with obesity, insulin resistance, and endothelial dysfunction. A potential role for cytokines originating from adipose tissue? *Arterioscler. Thromb. Vasc. Biol.* **19**: 972–978.
91. Crook, M. A., P. Tutt, and J. C. Pickup. 1993. Elevated serum sialic acid concentration in NIDDM and its relationship to blood pressure and retinopathy. *Diabetes Care.* **16**: 57–60.
92. Pickup, J. C., M. B. Mattock, G. D. Chusney, and D. Burt. 1997. NIDDM as a disease of the innate immune system: association of acute-phase reactants and interleukin-6 with metabolic syndrome X. *Diabetologia.* **40**: 1286–1292.
93. Pradhan, A. D., J. E. Manson, N. Rifai, J. E. Buring, and P. M. Ridker. 2001. C-reactive protein, interleukin 6, and risk of developing type 2 diabetes mellitus. *J. Am. Med. Assoc.* **286**: 327–334.
94. Hotamisligil, G. S., P. Arner, J. F. Caro, R. L. Atkinson, and B. M. Spiegelman. 1995. Increased adipose tissue expression of tumor necrosis factor- α in human obesity and insulin resistance. *J. Clin. Invest.* **95**: 2409–2415.
95. Ziccardi, P., F. Nappo, G. Giugliano, K. Esposito, R. Martella, M. Ciuffi, F. D'Andrea, A. M. Molinari, and D. Giugliano. 2002. Reduction of inflammatory cytokine concentrations and improvement of endothelial functions in obese women after weight loss over one year. *Circulation.* **105**: 804–809.
96. Hotamisligil, G. S., and B. M. Spiegelman. 1994. Tumor necrosis factor α : a key component of the obesity-diabetes link. *Diabetes.* **43**: 1271–1278.
97. Hofmann, C., K. Lorenz, S. S. Braithwaite, J. R. Colca, B. J. Palazuk, G. S. Hotamisligil, and B. M. Spiegelman. 1994. Altered gene expression for tumor necrosis factor- α and its receptors during drug and dietary modulation of insulin resistance. *Endocrinology.* **134**: 264–270.
98. Uysal, K. T., S. M. Wiesbrock, M. W. Marino, and G. S. Hotamisligil. 1997. Protection from obesity-induced insulin resistance in mice lacking TNF- α function. *Nature.* **389**: 610–614.
99. Saghizadeh, M., J. M. Ong, W. T. Garvey, R. R. Henry, and P. A. Kern. 1996. The expression of TNF α by human muscle. Relationship to insulin resistance. *J. Clin. Invest.* **97**: 1111–1116.
100. Gao, Z., D. Hwang, F. Bataille, M. Lefevre, D. York, M. J. Quon, and J. Ye. 2002. Serine phosphorylation of insulin receptor substrate 1 by inhibitor kappa B kinase complex. *J. Biol. Chem.* **277**: 48115–48121.
101. Stephens, J. M., and P. H. Pekala. 1991. Transcriptional repression of the GLUT4 and C/EBP genes in 3T3-L1 adipocytes by tumor necrosis factor- α . *J. Biol. Chem.* **266**: 21839–21845.
102. Zhang, B., J. Berger, E. Hu, D. Szalkowski, S. White-Carrington, B. M. Spiegelman, and D. E. Moller. 1996. Negative regulation of peroxisome proliferator-activated receptor- γ gene expression contributes to the antiadipogenic effects of tumor necrosis factor- α . *Mol. Endocrinol.* **10**: 1457–1466.
103. Bruun, J. M., A. S. Lihn, C. Verdich, S. B. Pedersen, S. Toubro, P. Astrup, and B. Richelsen. 2003. Regulation of adiponectin by adipose tissue-derived cytokines: in vivo and in vitro investigations in humans. *Am. J. Physiol. Endocrinol. Metab.* **285**: E527–E533.
104. Matsuzawa, Y., T. Funahashi, S. Kihara, and I. Shimomura. 2004. Adiponectin and metabolic syndrome. *Arterioscler. Thromb. Vasc. Biol.* **24**: 29–33.
105. Ahima, R. S., and J. S. Flier. 2000. Leptin. *Annu. Rev. Physiol.* **62**: 413–437.
106. Sica, A., J. M. Wang, F. Colotta, E. Dejana, A. Mantovani, J. J. Oppenheim, C. G. Larsen, C. O. Zachariae, and K. Matsushima. 1999. Monocyte chemotactic and activating factor gene expression induced in endothelial cells by IL-1 and tumor necrosis factor. *J. Immunol.* **144**: 3034–3038.
107. van der Poll, T., J. A. Romijn, E. Endert, J. J. Borm, H. R. Buller, and H. P. Sauerwein. 1991. Tumor necrosis factor mimics the metabolic response to acute infection in healthy humans. *Am. J. Physiol.* **261**: E457–E465.
108. Kubaszek, A., J. Pihlajamaki, V. Komarovski, V. Lindi, J. Lindstrom, J. Eriksson, T. T. Valle, H. Hamalainen, P. Ilanne-Parikka, S. Keinanen-Kiukaanniemi, et al. 2003. Promoter polymorphisms of the TNF- α (G-308A) and IL-6 (C-174G) genes predict the conversion from impaired glucose tolerance to type 2 diabetes: the Finnish Diabetes Prevention Study. *Diabetes.* **52**: 1872–1876.
109. Ofei, F., S. Hurel, J. Newkirk, M. Sopwith, and R. Taylor. 1996. Effects of an engineered human anti-TNF- α antibody (CDP571) on insulin sensitivity and glycemic control in patients with NIDDM. *Diabetes.* **45**: 881–885.
110. Bernstein, L. E., J. Berry, S. Kim, B. Canavan, and S. K. Grinspoon. 2006. Effects of etanercept in patients with the metabolic syndrome. *Arch. Intern. Med.* **166**: 902–908.
111. Yazdani-Biuki, B., H. Stelzl, H. P. Brezinschek, J. Hermann, T. Mueller, P. Krippel, W. Graninger, and T. C. Wascher. 2004. Improvement of insulin sensitivity in insulin resistant subjects during prolonged treatment with anti-TNF- α antibody infliximab. *Eur. J. Clin. Invest.* **34**: 641–642.
112. Huvers, F. C., C. Popa, M. G. Netea, F. H. J. van den Hoogen, and C. J. Tack. 2007. Improved insulin sensitivity by anti-TNF- α antibody treatment in patients with rheumatic diseases. *Ann. Rheum. Dis.* In press.
113. Jain, M. K., and P. M. Ridker. 2005. Anti-inflammatory effects of statins: clinical evidence and basic mechanisms. *Nat. Rev. Drug Discov.* **4**: 977–987.
114. Lehrke, M., and M. A. Lazar. 2005. The many faces of PPAR γ . *Cell.* **123**: 993–999.